

Coil-Lock ... Hold-in-Device

From Power Quality Solutions Inc.

Coil-Lock Applications Relays, contactors, and motor starters are used extensively in commercial and industrial facilities to control business machines and process equipment. These devices often have a low tolerance to electric service voltage sags, and are diagnosed as “weak links” in automated production lines. During common voltage sags, the solenoid coils in these motor-driven systems may de-energize long enough to cause the power circuit mechanical contacts to open, and the connected electrical equipment to shutdown. This situation can disrupt business operations and impact an entire manufacturing facility. The Coil-Lock eliminates costly process downtime, installs in minutes, and can be a cost-effective alternative to other voltage sag protection methods. The Coil-Lock product is available in different models to be compatible with most relays, contactors, or solenoid coils, and is ideal for protecting master control relays, and E-stop circuits.

The Coil-Lock is designed to ensure that at any time input voltage is present (down to ~25% of nominal voltage), the protected AC coil will maintain enough energy to hold-in the critical process element. When the input voltage goes below 25% of nominal, the Coil-Lock releases the coil, thereby ensuring that safety is not compromised, and the “on/off state” operation of the existing process functions as intended. The key to properly applying Coil-Locks is to determine the DC resistance of the AC coil of the relay/contactant unit you want to protect from deep voltage sags. Once you have the AC coil’s DC resistance value, the next step is to select the appropriate model Coil-Lock listed on this sheet.



A typical Coil-Lock weighs approximately 5 oz. (0.14kg) and measures 4” x 2 3/8” x 1 3/4”.

Coil-Lock Specifications

Momentary Voltage Sag Range: Provides continuous output voltage to hold-in relay and contactor coils for all IEEE Std. P1159 defined voltage sags to approximately 25% of nominal

Interruption Ride-Through Range: Designed to act as a discrete on/off device and will turn off the coil voltage if the Coil-Lock input voltage is interrupted for a few cycles (depending on the relay/contactant rating and vendor model)

Coil Inrush Current: Provides required high inrush coil current during startup

Transient Surge Protection: Provides transient voltage surge suppression for the relay/contactant coil circuit

Transient Surge Withstand: Designed to survive ANSI/IEEE C62.41 Category A and Category B defined transient voltage surges to 6kV/500A

Applied Environment: Designed to be compatible with stress and vibration common to typical commercial and industrial applications

Ambient Temperature Operating Range: -10° C (14°F) to +55° C (131°F)

Steady-State Operating Voltage Range: Designed to operate normally within $\pm 10\%$ of nominal coil voltage

PQSI Coil-Lock Warranty Unconditional-free Coil-Lock replacement for one year from date of purchase. Neither PQSI nor its business associates are responsible for any production loss or damage caused by a Coil-Lock misapplication or Coil-Lock failure.

FOR TECHNICAL INFORMATION CONTACT:
Power Quality Solutions Inc.

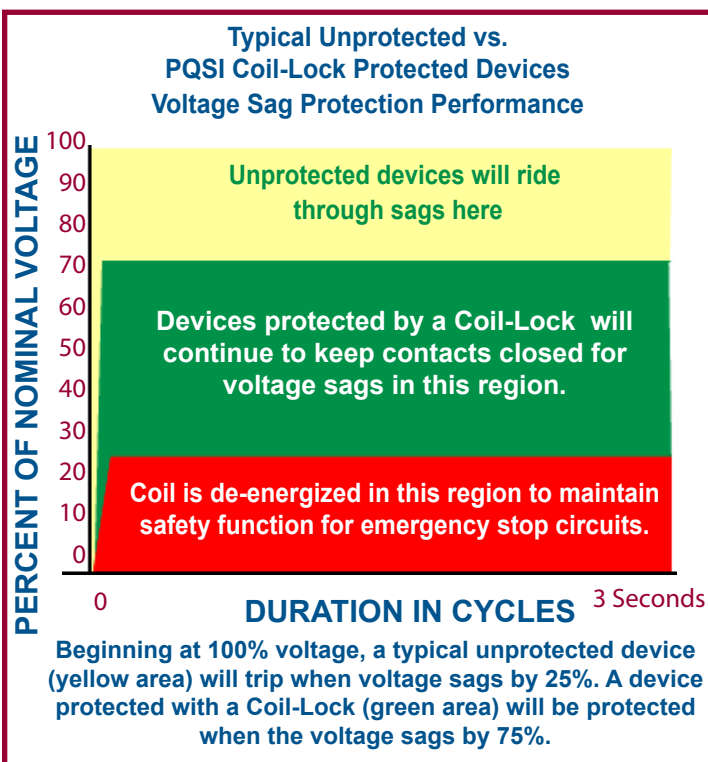

12529 Coral Reef Circle -- Knoxville, TN 37922-5490
Phone: 865-671-8364 Fax: 800-881-2893



Coil-Lock Installation Procedures

- Step #1** – Remove wires A and B, shown in Figure 1, from the relay/contactor coil and connect to octal mounting base socket terminals 1 and 2, shown in Figure 2.
- Step #2** – Connect new wires from the octal mounting base socket terminals 3 and 4 to the relay/contactor where you removed the wires in Step #1.
- Step #3** – Figure 3 below shows the physical orientation, locations, and terminal numbers of the octal mounting base socket to provide a clearer understanding of terminal connections.

Application Advisories and Notes

- [a] Coil-Locks are intended to interface with AC solenoid coil operated devices and may not be compatible with DC coil operated devices or coils that have integral electronic circuitry as part of their operating strategy.
- [b] In some AC coil applications, coil energy “discharge” devices such as rectifier diodes are pre-wired across the AC coil. These devices should be removed before installing the Coil-Lock. After the Coil-Lock is installed, the Coil-Lock provides the required AC coil discharge feature.
- [c] For proper Coil-Lock operation, observe conventional isolation and grounding techniques on all Coil-Lock terminal points and avoid any “sneak” ground paths.
- [d] The Coil-Lock should be installed in an electrical / fire enclosure that complies with the applicable safety standard.
- [e]  **Safety Caution:** Read all instructions thoroughly prior to installation. If this equipment is used in a manner not specified, the protection provided by this equipment may be impaired.
- [f]  **Safety Caution:** Risk of electric shock if this equipment is not connected in accordance with Figures 2 and 3 below.
- [g] On equipment with LEDs to indicate the coil device is energized, while the coil device will operate properly, the LED may not illuminate. Since the Coil-Lock output voltage is polarized, simply reverse the Coil-Lock connections on the coil device.

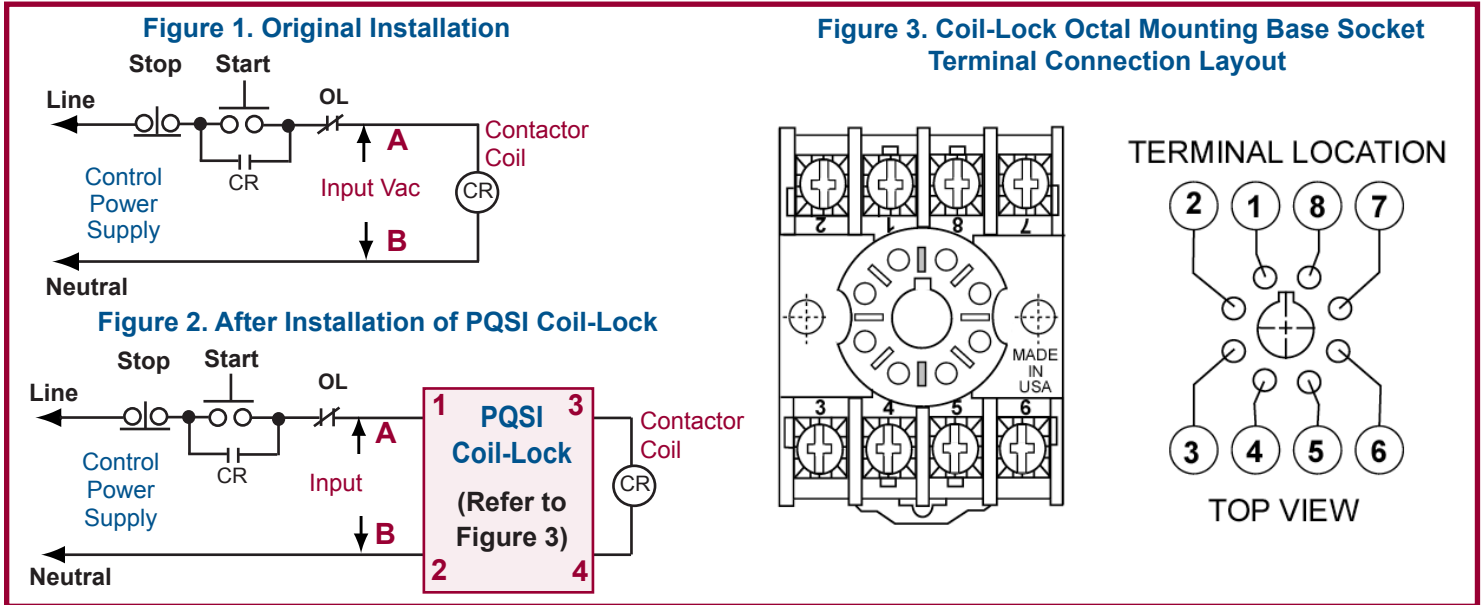

COIL-LOCK ~ 120V and 240V Models* (All Coil-Locks Include Din-Rail Octal Mounting Base Socket)

Model Number	AC Coil Resistance Measured w/DC Ohmmeter	Comments
1000-120V	801 to 4.5k Ohms [1]	UL Compliant File E255764
1001-120V	201 to 800 Ohms [1]	UL Compliant File E255764
1002-120V	8 to 200 Ohms [1]	UL Compliant File E255764
1002-120V-CE	8 to 200 Ohms [1]	 UL & CE Compliant (50 ma no load, 0.4 Amps w/8 Ohm Coil)
1003-120V	3 to 7.9 Ohms [1]	UL Compliant File E255764
1001-240V	601 to 17.5k Ohms [2]	UL Compliant File E255764
1002-240V	155 to 600 Ohms [2]	UL Compliant File E255764
1003-240V	20 to 154 Ohms [2]	UL Compliant File E255764

[1] For use with 100 to 125 Vac 50/60 Hz relays and contactors only.
 [2] For use with 200 to 240 Vac 50/60 Hz relays and contactors only.

***FOR PRICING**
 Call 865-671-8364
 or e-mail customerservice@pqsi.com